

PER SCEGLIERE IL SUPPORTO ANTIVIBRANTE CORRETTO BISOGNA CONOSCERE:

1. PESO STATICO della macchina e NUMERO DEI PUNTI DI APPOGGIO con rispettivo carico gravante.
2. FREQUENZA ECCITANTE determinata dal corpo rotante con r.p.m. più bassa.
3. LUOGO D'INSTALLAZIONE: se la macchina viene installata in una zona sismica, in copertura, se è soggetta alle forze del vento o in una zona con elevata presenza di nebbie saline o altri agenti aggressivi.
4. TEMPERATURA D'IMPIEGO: bisogna tenere in considerazione le temperature alle quali saranno soggetti i supporti antivibranti.

L'INSTALLAZIONE È CORRETTA QUANDO TUTTI I SUPPORTI INSTALLATI PRESENTANO LA STESSA FRECCIA ELASTICA.

Se le basi di appoggio dei diversi supporti antivibranti non sono tra loro a livello, è necessario compensare tale mancanza utilizzando appositi registri (MARTINETTI).

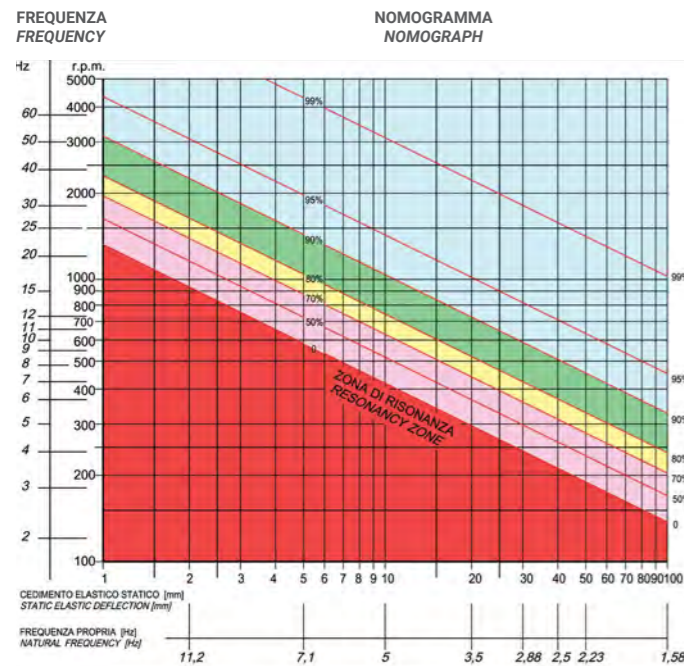

TO CHOOSE THE CORRECT ANTI-VIBRATION MOUNT, YOU MUST KNOW:

1. The **STATIC WEIGHT** of the machine and the **NUMBER OF SUPPORT POINTS** with their respective loads;
2. The **EXCITATION FREQUENCY** determined by the rotating body at the lowest r.p.m..
3. **INSTALLATION SITE**: if the machine is installed in a seismic area, on the roof, if it is subject to wind forces or in an area with high presence of saline mists or other aggressive agents.
4. **WORKING TEMPERATURE**: the temperatures to which the anti-vibration mounts will be subject must be taken into consideration.

THE INSTALLATION IS CORRECT WHEN ALL THE INSTALLED MOUNTS HAVE THE SAME ELASTIC DEFLECTION.

If the support bases of the different anti-vibration mounts are not among them at level, it is necessary to compensate for this lack using special registers (JACKS).

Il diagramma degli isolamenti, riassume graficamente, le relazioni intercorrenti tra la freccia elastica espressa in mm, il regime vibrante in r.p.m. o i cicli/mm e il grado di isolamento espresso in %.

The insulation diagram shows graphically the ratios between the elastic deflections in mm, the vibration speed in r.p.m. or cycles/mm and the degree of insulation as a %.



**SUPPORTI ANTIVIBRANTI PLURIMOLLA
MULTIPLE SPRINGS MOUNTS**

Soleco engineering s.r.l. non si assume responsabilità nei casi dove si evidenzia l'errata installazione del supporto.

Soleco Engineering S.r.l. declines all responsibility in cases where the incorrect installation of the support is detected.

**SERIE RQ
RQ SERIES**

p. 6

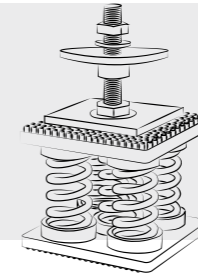

**SERIE R
R SERIES**

p. 8

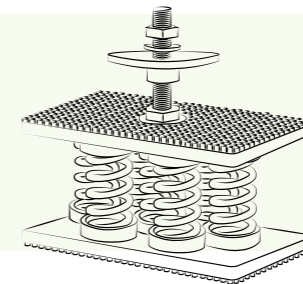

**SERIE RF
RF SERIES**

p. 10

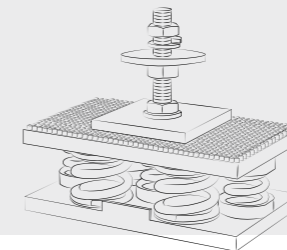

**SERIE G
G SERIES**

p. 12

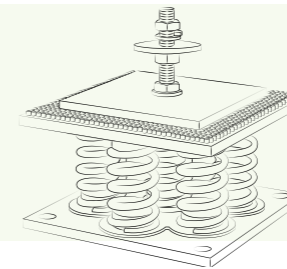

**SERVIZIO IN KIT
KIT SERVICE**

p. 14

SERIE RQ - R - RF - G

RQ - R - RF - G SERIES

CARATTERISTICHE COSTRUTTIVE

- Molle in acciaio armonico UNI EN 10270-1 SH con superficie protetta da trattamento cataforetico.
- 2 placche, che contengono le molle, formate da piastre in acciaio zincato secondo UNI ISO 2081 Fe/Zn12c1A bianca rivestite in elastomero termoplastico con elevata resistenza alla lacerazione, all'invecchiamento atmosferico, all'ozono, ai detergenti, ai raggi UV e alle temperature da -45°C a +110°C.
- La superficie delle placche presenta rilievi deformabili che consentono all'antivibrante caricato di stazionare per attrito e ridurre la trasmissione del rumore.

A RICHIESTA

- Verniciatura delle molle a polvere poliesteri termoidurente, secondo la nostra tabella RAL.

MANUFACTURING CHARACTERISTICS

- Springs in harmonic steel UNI EN 10270-1 SH with surface protected by cathoretic treatment.
- 2 plates, which contain the springs, formed by galvanized steel plates according to UNI ISO 2081 Fe/Zn12c1A white coated in thermoplastic elastomer with high resistance to tearing, atmospheric aging, ozone, detergents, UV rays and temperatures from -45°C to +110°C.
- The surface of the plates has slip-proof, flexible embossing which allow the charged anti-vibration mount to stand by friction and at the same time reduce the transmission of noise.

ON REQUEST

- Painting of the spring with thermosetting polyester powder, according to our RAL chart.

ACCESSORI

ACCESSORIES

A RICHIESTA

- MARTINETTO in acciaio zincato o in acciaio inox AISI 316, per agevolare la registrazione della quota macchina;
- Piastra porta martinetto in acciaio zincato o in acciaio INOX AISI 316 per distribuire il carico sulle molle.

CODE	DESCRIPTION	SUITABLE FOR SERIES
0000MRM12/000	jack M12	RQ - R - RF - G
0000MRM16/000	jack M16	RQ - R - RF - G
0000MRM20M16/	jack M20/16	RQ - R - RF - G
0RFRPM000000Z	jack holder plate 80x80	RQ - R - RF - G
0RF0PM000000Z	jack holder plate 100x170	R - RF
0G00PM000000Z	jack holder plate 150x150	G

ON REQUEST

- JACK in galvanized steel or in stainless steel AISI 316, to facilitate the registration of the machine level;
- Jack holder plate in galvanized steel or stainless steel AISI 316 to distribute the load on the springs.

SERIE RQ

- 5 MOLLE IN 3 ALTEZZE:
- RQZb - RQXb
 - RQZr - RQXr
 - RQZ - RQX.

RQ SERIES

- 5 SPRINGS IN 3 HEIGHTS:
- RQZb - RQXb
 - RQZr - RQXr
 - RQZ - RQX.



SERIE RQ

- PIASTRA PORTA MARTINETTO RIDOTTA 80x80x25

RQ SERIES

- REDUCED JACK HOLDER PLATE 80x80x25



SERIE R

- 7 MOLLE IN 3 ALTEZZE:
- RZb - RXb
 - RZr - RXr
 - RZ - RX.

R SERIES

- 7 SPRINGS IN 3 HEIGHTS:
- RZb - RXb
 - RZr - RXr
 - RZ - RX.

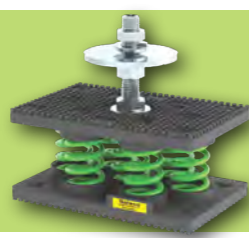

SERIE R

- PIASTRA PORTA MARTINETTO RIDOTTA 80x80x25
- PIASTRA PORTA MARTINETTO NORMALE 100x170x25

R SERIES

- REDUCED JACK HOLDER PLATE 80x80x25
- NORMAL JACK HOLDER PLATE 100x170x25



SERIE RF

- 7 MOLLE IN 3 ALTEZZE:
- RFZb - RFXb
 - RFZr - RFXr
 - RFZ - RFX.

RF SERIES

- 7 SPRINGS IN 3 HEIGHTS:
- RFZb - RFXb
 - RFZr - RFXr
 - RFZ - RFX.

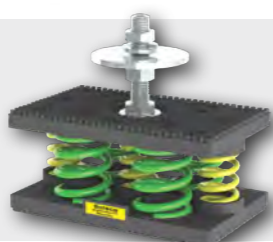

SERIE RF

- PIASTRA PORTA MARTINETTO RIDOTTA 80x80x25
- PIASTRA PORTA MARTINETTO NORMALE 100x170x25

RF SERIES

- REDUCED JACK HOLDER PLATE 80x80x25
- NORMAL JACK HOLDER PLATE 100x170x25

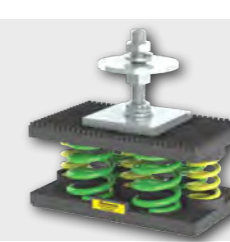

SERIE G

- 7 MOLLE IN 3 ALTEZZE:
- GWr - GVr
 - GW - GV
 - GWH - GVH.

G SERIES

- 7 SPRINGS IN 3 HEIGHTS:
- GWr - GVr
 - GW - GV
 - GWH - GVH.



SERIE G

- PIASTRA PORTA MARTINETTO RIDOTTA 80x80x25
- PIASTRA PORTA MARTINETTO NORMALE 150x150x25

G SERIES

- REDUCED JACK HOLDER PLATE 80x80x25
- NORMAL JACK HOLDER PLATE 150x150x25



SERIE RQ

RQ SERIES

RQZb - RQXb

1

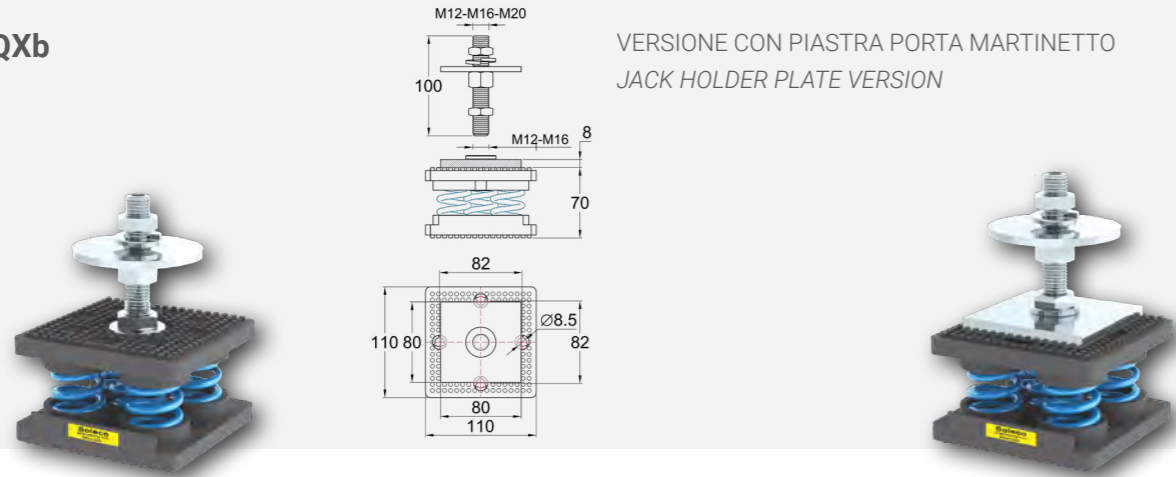

RQZr - RQXr

2

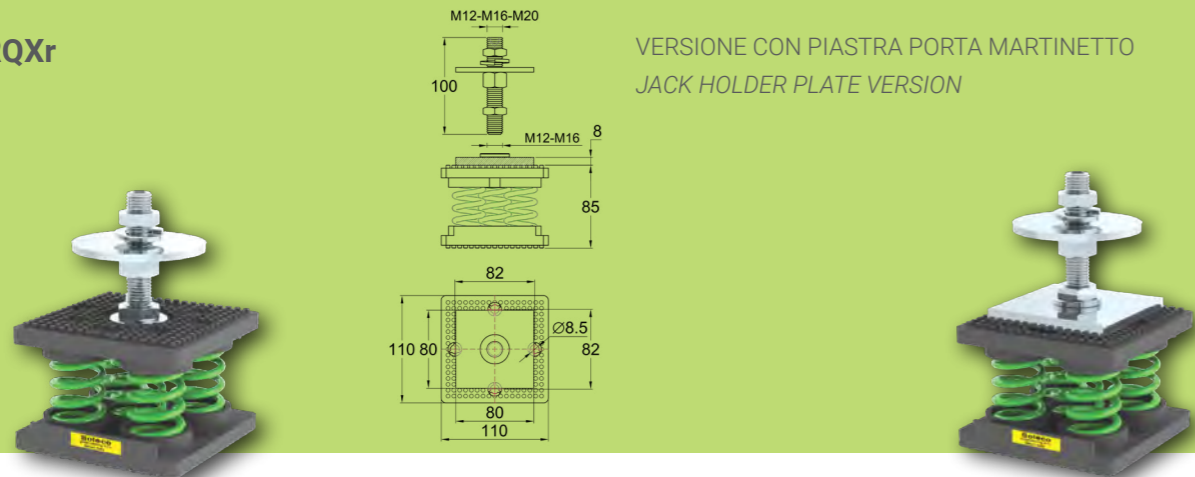

RQZ - RQX

3

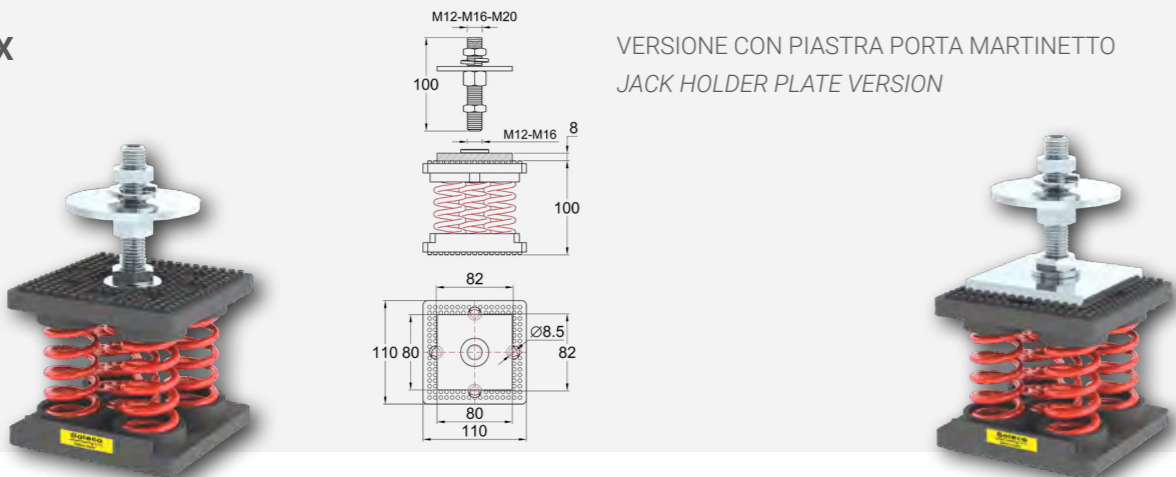

RQZb - RQXb

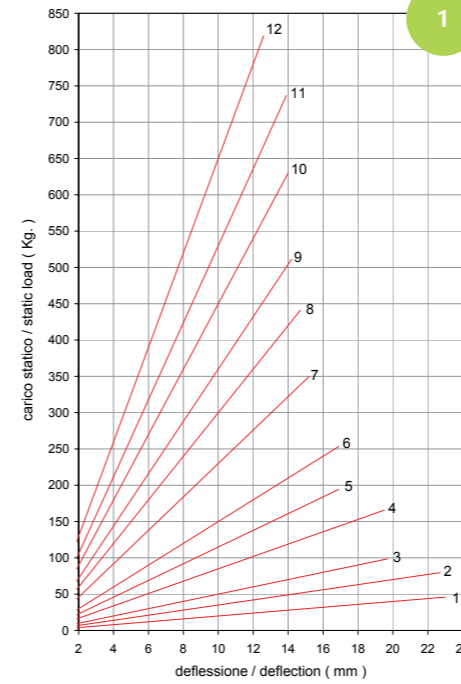

RQZr - RQXr

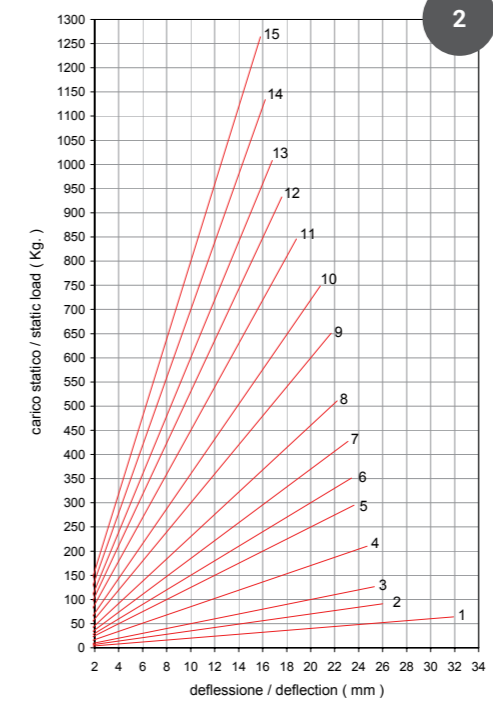

RQZ - RQX

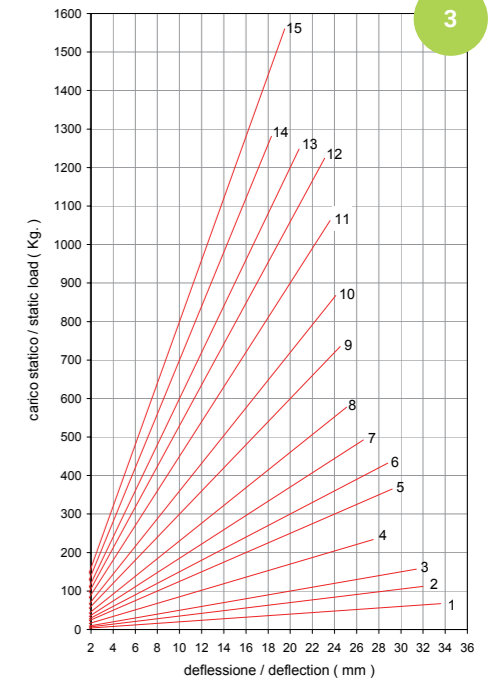

N.	MODEL	WEIGHT (kg)	k
1	RQZb 500	1.01	2.0
2	RQZb 501	1.02	3.5
3	RQZb 502	1.05	5.0
4	RQZb 503	1.06	8.5
5	RQZb 504	1.11	11.5
6	RQZb 505	1.11	15.0
7	RQZb 508	1.21	23.0
8	RQXb 510	1.18	30.0
9	RQXb 5101	1.21	36.0
10	RQXb 511	1.37	45.0
11	RQXb 512	1.25	53.0
12	RQXb 513	1.30	65.0

N.	MODEL	WEIGHT (kg)	k
1	RQZr 500	1.07	2.0
2	RQZr 501	1.14	3.5
3	RQZr 502	1.13	5.0
4	RQZr 503	1.19	8.5
5	RQXr 501b	1.20	12.5
6	RQZr 505	1.21	15.0
7	RQXr 502	1.28	18.5
8	RQZr 508	1.27	23.0
9	RQXr 503	1.34	30.0
10	RQZr 512	1.35	36.0
11	RQXr 504	1.41	45.0
12	RQZr 520	1.39	53.0
13	RQXr 507	1.42	60.0
14	RQZr 522	1.48	70.0
15	RQZr 524	1.51	80.0

N.	MODEL	WEIGHT (kg)	k
1	RQZ 500	1.15	2.0
2	RQZ 501	1.17	3.5
3	RQZ 502	1.18	5.0
4	RQZ 503	1.35	8.5
5	RQX 501	1.36	12.5
6	RQZ 505	1.33	15.0
7	RQX 502	1.40	18.5
8	RQZ 508	1.40	23.0
9	RQX 503	1.47	30.0
10	RQZ 512	1.53	36.0
11	RQX 504	1.60	45.0
12	RQZ 520	1.62	53.0
13	RQX 507	1.72	60.0
14	RQZ 522	1.75	70.0
15	RQZ 524	1.69	80.0

CARATTERISTICHE TECNICHE E PERSONALIZZAZIONI
A PAGINA 4 E 5

MANUFACTURING CHARACTERISTICS AND CUSTOMIZATIONS
ON PAGE 4 AND 5

SERIE R R SERIES

RZb - RXb

1

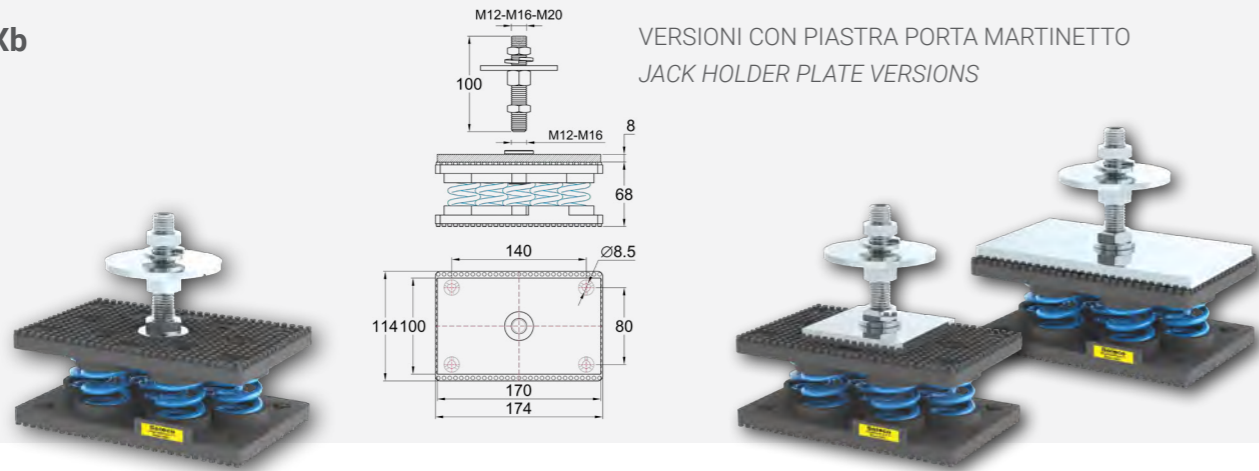

RZr - RXr

2

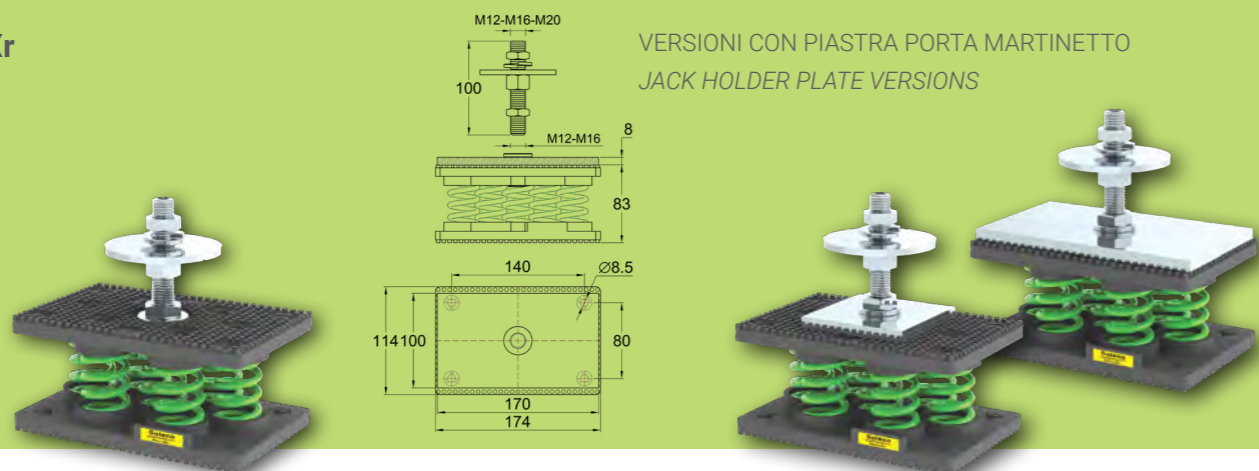

RZ - RX

3

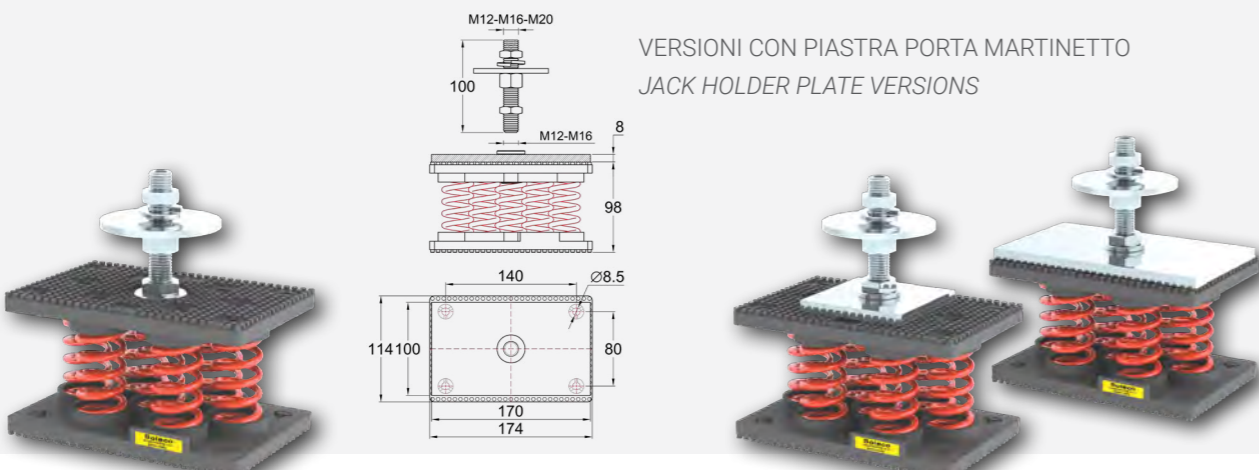

RZb - RXb

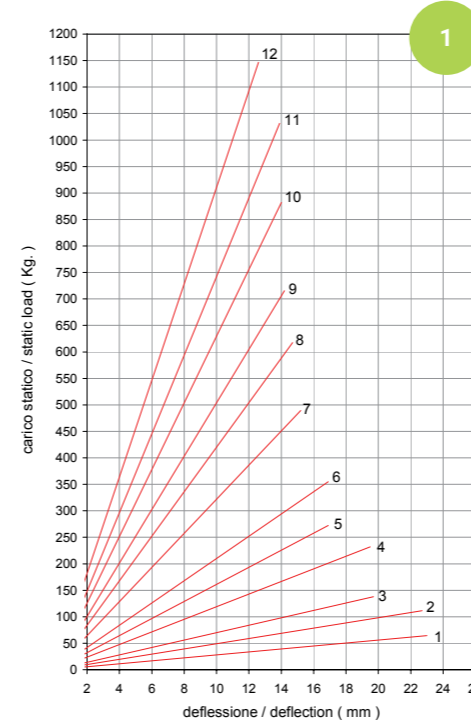

RZr - RXr

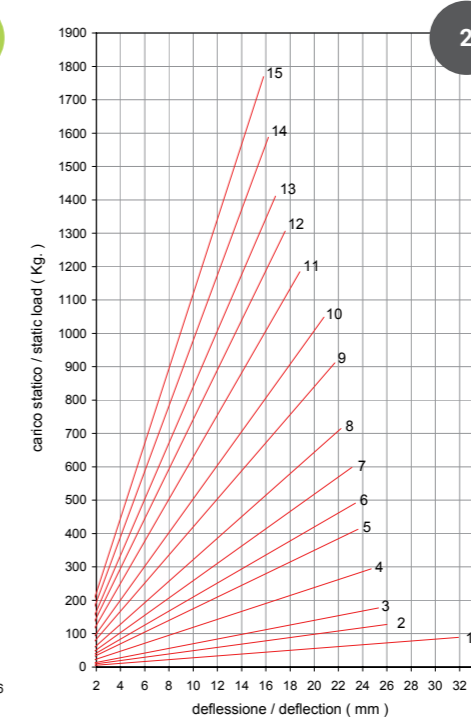

RZ - RX

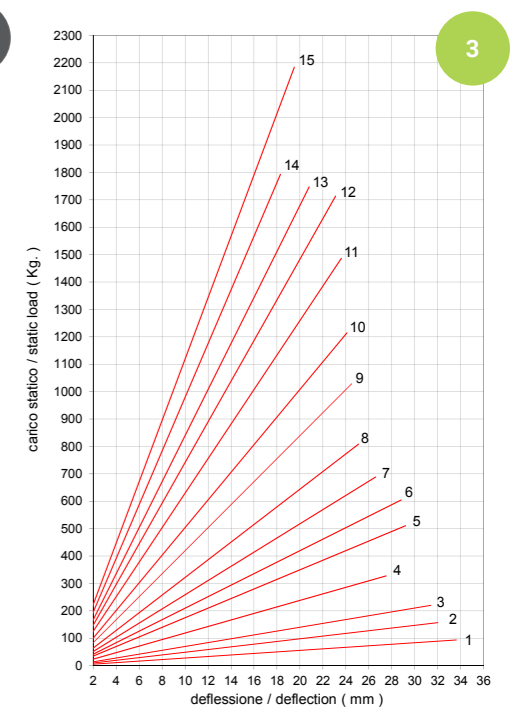

N.	MODEL	WEIGHT (kg)	k
1	RZb 700	1.69	2.8
2	RZb 701	1.70	4.9
3	RZb 702	1.74	7.0
4	RZb 703	1.76	11.9
5	RZb 704	1.83	16.1
6	RZb 705	1.83	21.0
7	RZb 708	1.97	32.2
8	RXb 710	1.93	42.0
9	RXb 7101	1.97	50.4
10	RXb 711	2.19	63.0
11	RXb 712	2.02	74.2
12	RXb 713	2.09	91.0

N.	MODEL	WEIGHT (kg)	k
1	RZr 700	1.77	2.8
2	RZr 701	1.87	4.9
3	RZr 702	1.86	7.0
4	RZr 703	1.94	11.9
5	RXr 701	1.95	17.5
6	RZr 705	1.97	21.0
7	RXr 702	2.07	25.9
8	RZr 708	2.05	32.2
9	RXr 703	2.15	42.0
10	RZr 712	2.16	50.4
11	RXr 704	2.25	63.0
12	RZr 720	2.20	74.2
13	RXr 707	2.26	84.0
14	RZr 722	2.35	98.0
15	RZr 724	2.39	112.0

N.	MODEL	WEIGHT (kg)	k
1	RZ 700	1.88	2.8
2	RZ 701	1.91	4.9
3	RZ 702	1.93	7.0
4	RZ 703	2.16	11.9
5	RX 701	2.18	17.5
6	RZ 705	2.14	21.0
7	RX 702	2.23	25.9
8	RZ 708	2.23	32.2
9	RX 703	2.33	42.0
10	RZ 712	2.42	50.4
11	RX 704	2.51	63.0
12	RZ 720	2.54	74.2
13	RX 707	2.68	84.0
14	RZ 722	2.72	98.0
15	RZ 724	2.64	112.0

CARATTERISTICHE TECNICHE E PERSONALIZZAZIONI
A PAGINA 4 E 5

MANUFACTURING CHARACTERISTICS AND CUSTOMIZATIONS
ON PAGE 4 AND 5

SERIE RF

RF SERIES

RFZb - RFXb

1

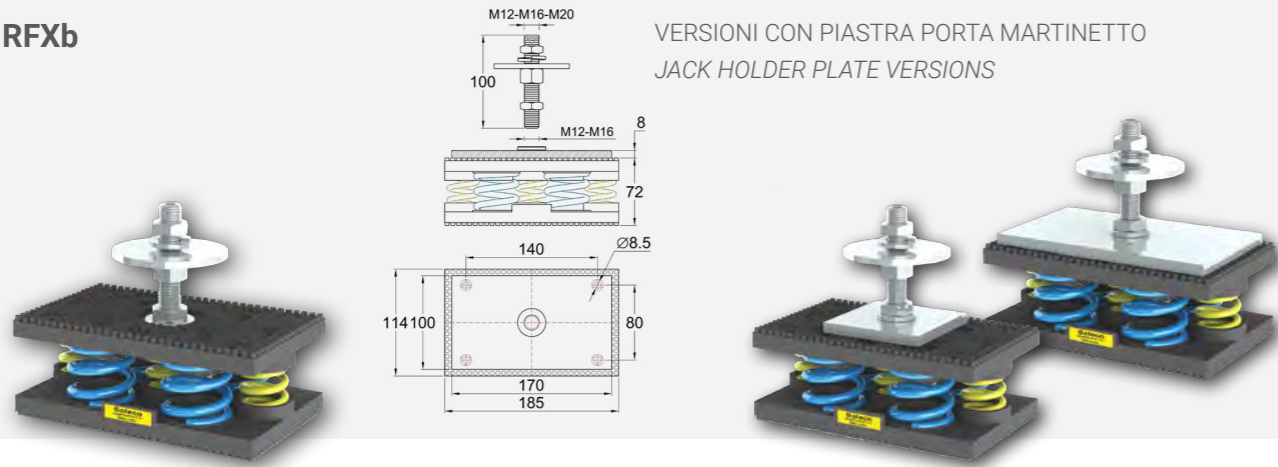

VERSIONI CON PIASTRA PORTA MARTINETTO
JACK HOLDER PLATE VERSIONS

RFZb - RFXb

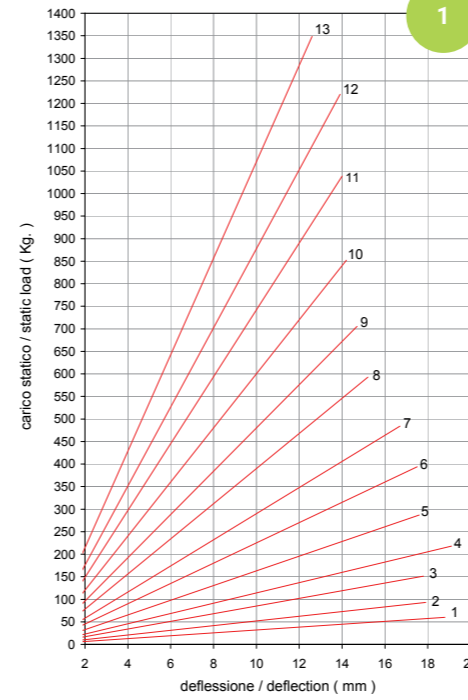

1

RFZr - RFXr

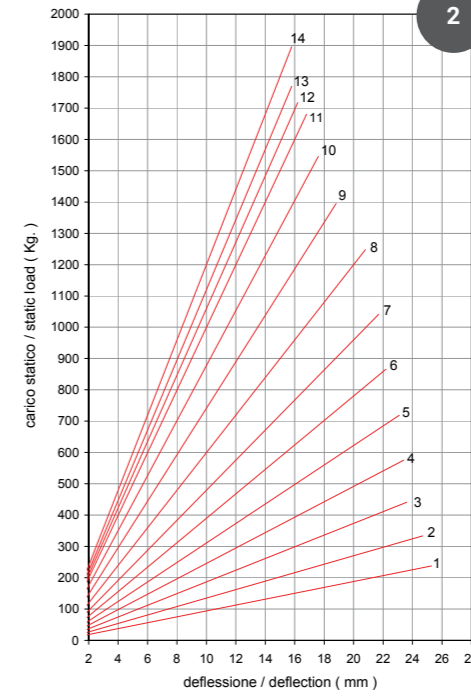

2

RFZ - RFX

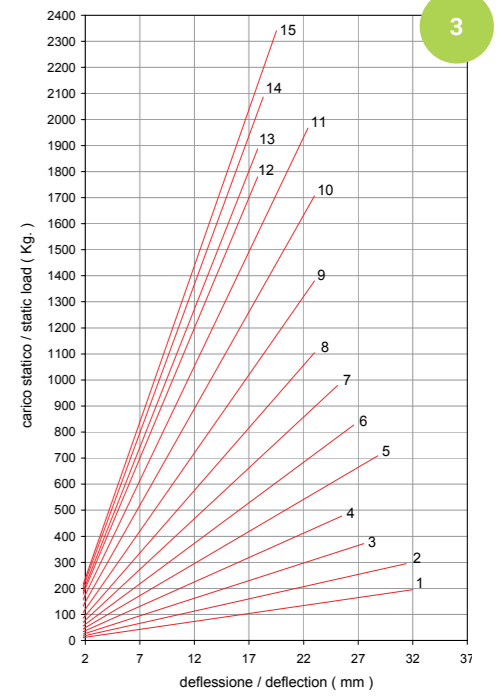

3

RFZr - RFXr

2

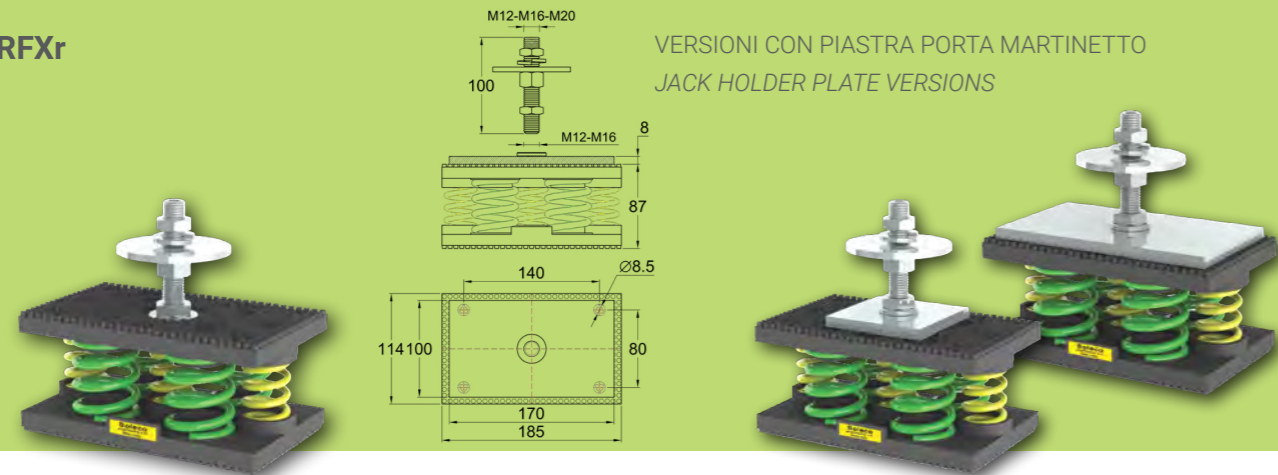

VERSIONI CON PIASTRA PORTA MARTINETTO
JACK HOLDER PLATE VERSIONS

N.	MODEL	WEIGHT (kg)	k
1	RFb 401 - Zb 300	1.90	3.2
2	RFb 402 - Zb 300	1.92	5.2
3	RFb 404 - Zb 301	1.96	8.5
4	RFb 405 - Zb 302	1.94	11.4
5	RFb 408 - Zb 303	2.03	16.3
6	RFb 480 - Zb 304	2.01	22.5
7	RFb 409 - Zb 305	2.12	29.0
8	RFb 409 - Zb 308	2.18	33.8
9	RFb 410 - Xb 310	2.18	48.0
10	RFb 410 - Xb 3101	2.20	51.6
11	RFb 412 - Xb 311	2.33	74.2
12	RFb 413 - Xb 312	2.33	87.8
13	RFb 414 - Xb 313	2.41	107.0

N.	MODEL	WEIGHT (kg)	k
1	RFr 404 - Zr 302	2.06	9.4
2	RFr 405 - Zr 303	2.10	13.5
3	RFr 408 - Xr 301	2.21	18.7
4	RFr 480 - Zr 305	2.21	24.6
5	RFr 409 - Xr 302	2.34	31.1
6	RFr 490 - Zr 308	2.34	39.0
7	RFr 410 - Xr 303	2.42	48.0
8	RFr 411 - Zr 312	2.50	60.0
9	RFr 412 - Xr 304	2.58	74.2
10	RFr 413 - Zr 320	2.68	87.8
11	RFr 4130 - Xr 307	2.65	100.0
12	RFr 4130 - Zr 322	2.73	106.0
13	RFr 4130 - Zr 324	2.75	112.0
14	RFr 414 - Zr 324	2.74	120.0

N.	MODEL	WEIGHT (kg)	k
1	RF 402 - Z 301	2.08	6.1
2	RF 404 - Z 302	2.23	9.4
3	RF 405 - Z 303	2.46	13.5
4	RF 408 - X 301	2.57	18.7
5	RF 480 - Z 305	2.56	24.6
6	RF 409 - X 302	2.59	31.1
7	RF 490 - Z 308	2.65	39.0
8	RF 410 - X 303	2.99	48.0
9	RF 411 - Z 312	3.05	60.0
10	RF 412 - X 304	3.08	74.2
11	RF 413 - Z 320	3.25	87.6
12	RF 4130 - X 307	3.56	100.0
13	RF 4130 - Z 322	3.58	106.0
14	RF 414 - Z 322	3.35	114.0
15	RF 414 - Z 324	3.32	120.0

RFZ - RFX

3

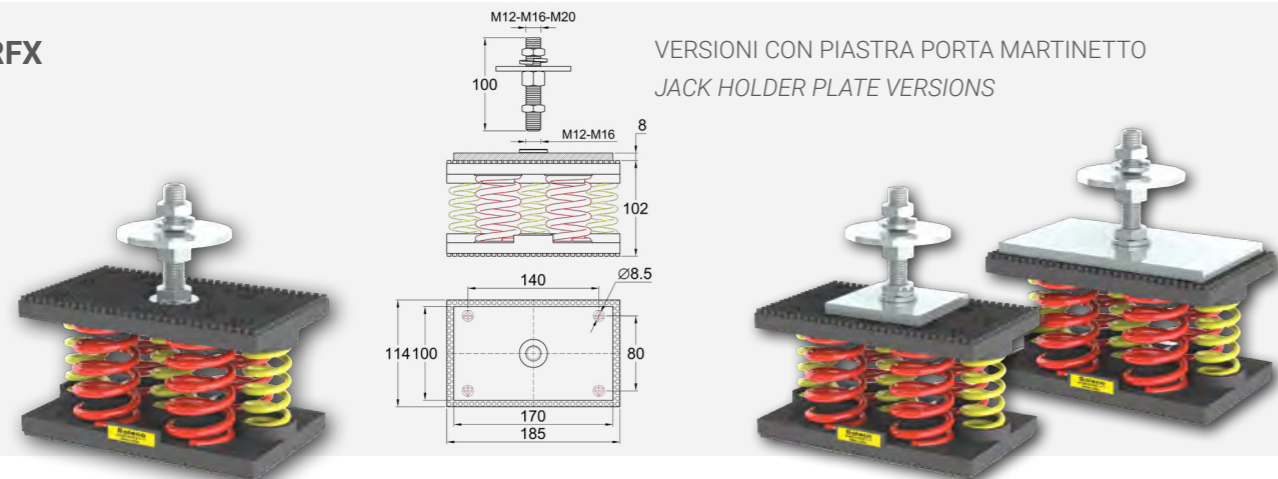

VERSIONI CON PIASTRA PORTA MARTINETTO
JACK HOLDER PLATE VERSIONS

CARATTERISTICHE TECNICHE E PERSONALIZZAZIONI
A PAGINA 4 E 5

MANUFACTURING CHARACTERISTICS AND CUSTOMIZATIONS
ON PAGE 4 AND 5

SERIE G G SERIES

GWr - GVr

1

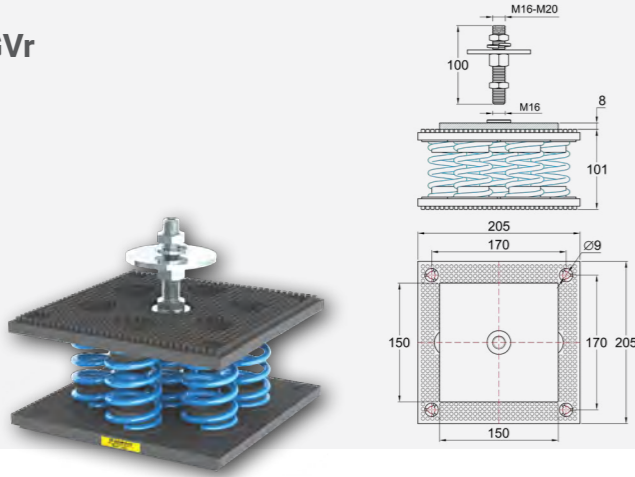

VERSIONI CON PIASTRA PORTA MARTINETTO
JACK HOLDER PLATE VERSIONS

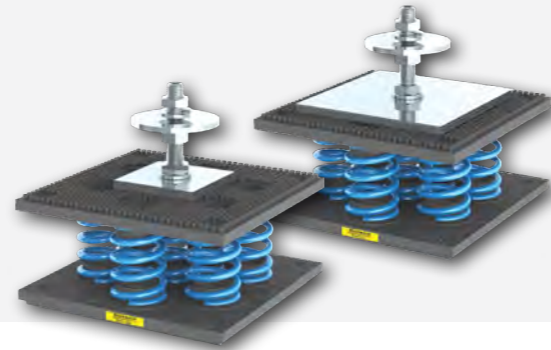

GW - GV

2

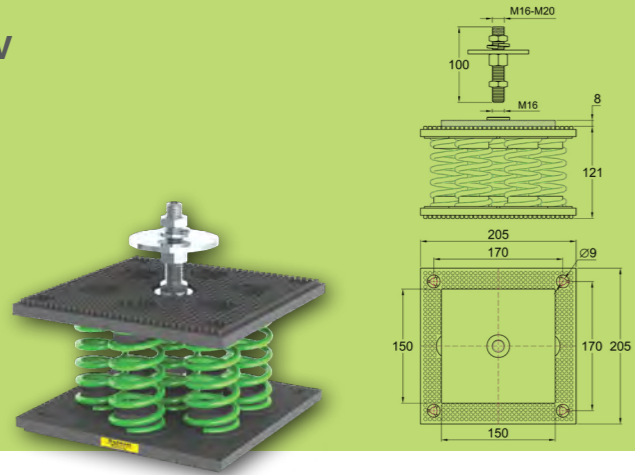

VERSIONI CON PIASTRA PORTA MARTINETTO
JACK HOLDER PLATE VERSIONS

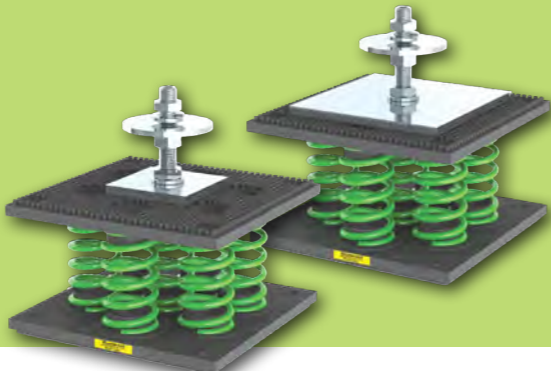

GWH - GVH

3

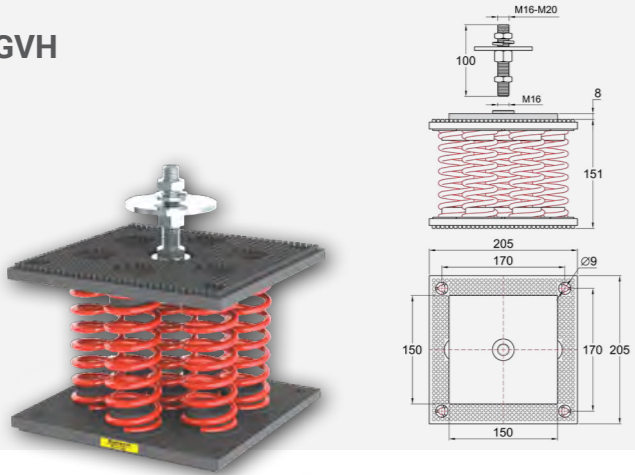

VERSIONI CON PIASTRA PORTA MARTINETTO
JACK HOLDER PLATE VERSIONS



GWr - GVr

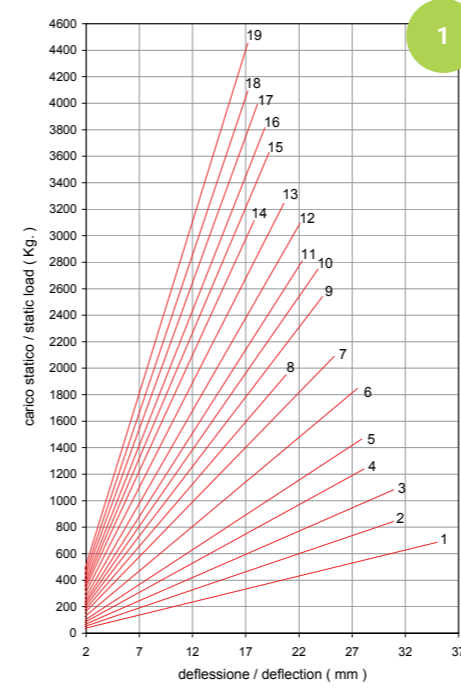

1

GW - GV

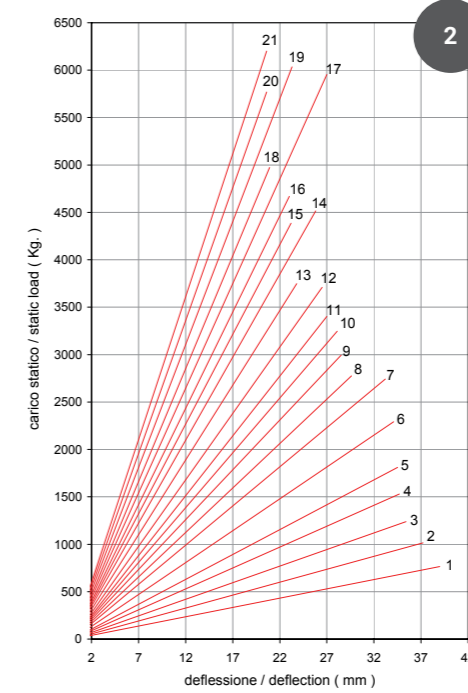

2

GWH - GVH

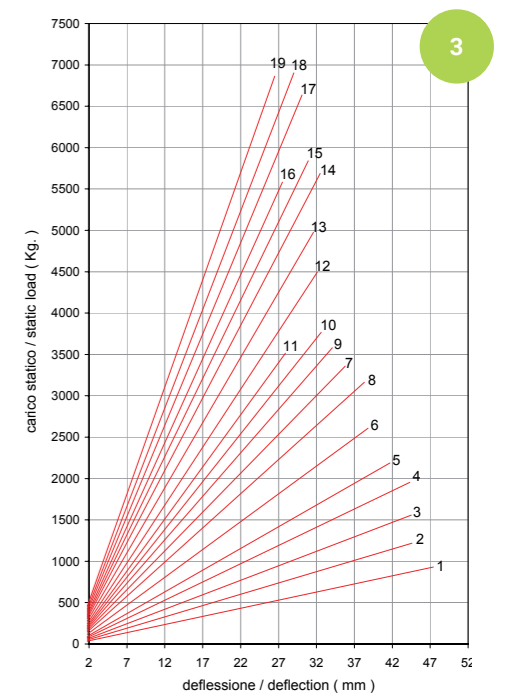

3

N.	MODEL	WEIGHT (kg)	k
1	GWr 708	3.85	19.6
2	GWr 709	4.09	27.3
3	GWr 712	4.29	35.0
4	GVr 714	4.52	44.1
5	GVr 720	4.72	52.5
6	GVr 722	4.83	67.2
7	GVr 730	5.07	82.6
8	GVr 7300	5.15	93.8
9	GVr 7301	5.31	105.0
10	GVr 7305	5.41	115.5
11	GVr 731	5.52	126.0
12	GVr 733	5.24	140.0
13	GVr 745	5.75	157.5
14	GVr 747	6.04	175.0
15	GVr 748	6.22	189.0
16	GVr 750	6.76	203.0
17	GVr 7501	6.55	220.5
18	GVr 7510	6.47	238.0
19	GVr 751	6.88	259.0

N.	MODEL	WEIGHT (kg)	k
1	GW 708	4.57	19.6
2	GW 709	4.86	27.3
3	GW 712	5.03	35.0
4	GV 714	5.38	44.1
5	GV 720	5.35	52.5
6	GV 722	6.12	67.2
7	GV 730	5.71	82.6
8	GV 7300	6.13	93.8
9	GV 7301	5.77	105.0
10	GV 7305	5.58	115.5
11	GV 731	6.20	126.0
12	GV 733	6.79	140.0
13	GV 745	7.44	157.5
14	GV 747	7.55	175.0
15	GV 748	7.59	189.0
16	GV 750	7.07	203.0
17	GV 7501	8.23	220.5
18	GV 7510	8.81	238.0
19	GV 751	8.85	259.0
20	GV 753	7.44	280.0
21	GV 755	8.12	301.0

N.	MODEL	WEIGHT (kg)	k
1	GWH 708	5.78	19.6
2	GWH 709	5.50	27.3
3	GWH 712	5.81	35.0
4	GVH 714	6.18	44.1
5	GVH 720	6.68	52.5
6	GVH 722	7.17	67.2
7	GVH 730	6.96	82.6
8	GVH 7300	6.85	93.8
9	GVH 7301	8.99	105.0
10	GVH 7305	8.46	115.5
11	GVH 731	9.68	126.0
12	GVH 733	8.98	140.0
13	GVH 745	8.99	157.5
14	GVH 747	9.33	175.0
15	GVH 748	10.03	189.0
16	GVH 750	10.46	203.0
17	GVH 7501	9.73	220.5
18	GVH 7510	10.42	238.0
19	GVH 751	11.19	259.0

CARATTERISTICHE TECNICHE E PERSONALIZZAZIONI
A PAGINA 4 E 5

MANUFACTURING CHARACTERISTICS AND CUSTOMIZATIONS
ON PAGE 4 AND 5

SERVIZIO KIT KIT SERVICE

SERVIZIO KIT

Per i Clienti che hanno una produzione standardizzata, proponiamo un servizio di preselezione in modo da fornire un kit di antivibranti adatti a ogni modello di macchina.

Con questo servizio si dimezzano i tempi di fornitura e si facilitano le fasi di installazione.

Per maggiori informazioni su questo servizio vi invitiamo a contattare i nostri uffici.

GUIDA ALL'INSTALLAZIONE

All'interno del kit viene inserita la documentazione tecnica riguardante i supporti antivibranti e le istruzioni per l'installazione degli antivibranti sotto la macchina.

Vengono inseriti i disegni delle macchine del Cliente, con i relativi codici e la spiegazione illustrata del posizionamento degli antivibranti.

Le guide possono essere personalizzate in diverse lingue e con il logo del Cliente.

IDEALE PER PRODUTTORI DI MACCHINE IN SERIE

KIT SERVICE

For Customers who have a production standardized, we offer a service of preselection in order to provide a kit of anti-vibration mounts suitable for each machine model.

With this service, delivery times are shorter and installation phases are facilitated.

For more information on this service, please contact our offices.

INSTALLATION GUIDE

Technical documentation provided inside the kit explains the characteristics of the mounts and the instruction for the installation of anti-vibration mounts under the machine.

The drawings of the Customer's machines are inserted, with the relative codes and the illustrated explanation of the positioning of the mounts.

The guides can be customized in different languages and with the Customer's logo.

IDEAL FOR PRODUCERS OF STANDARD MACHINES

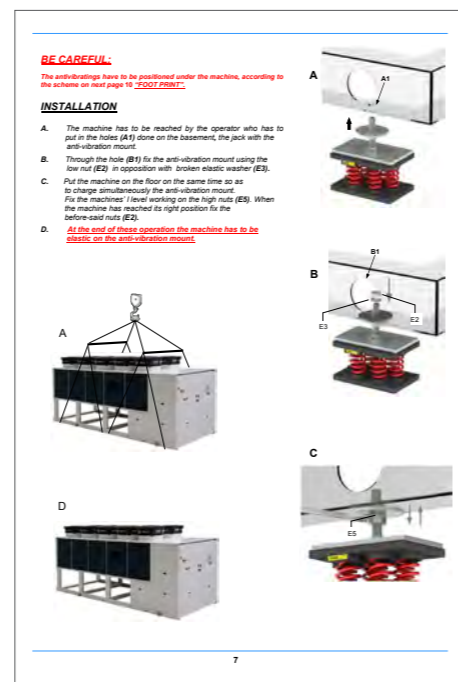

LIMITATORI DI SPINTA SISMICA SEISMIC SNUBBERS

LIMITATORI DI SPINTA SISMICA

Limitatori di spinta formati da staffe a L, con fori per l'ancoraggio verso terra, in acciaio UNI EN 10025-S235JR sabbiato, protette da trattamento cataforetico e verniciate a polvere poliesterica e tamponi elastomerici regolabili per bloccare l'unità.

Questi limitatori vengono installati a ridosso del basamento macchina ed effettuano un'azione contenitiva delle forze derivanti da sisma o dall'azione del vento impedendo gli spostamenti laterali dell'unità.

SEISMIC SNUBBER

Thrust limiters formed by L-shaped brackets, with holes for anchoring to the ground, in sandblasted UNI EN 10025-S235JR steel, protected by cathaphoretic treatment and polyester powder coated and adjustable elastomeric pads to block the unit.

These limiters are installed close to the machine base and carry out a containment action of the forces deriving from an earthquake or the action of the wind, preventing the lateral displacements of the unit.

