

## BELT CHARACTERISTICS

STANDARD WIDTHS (mm)	25	50	75	100
Weight (gr/m)	125	250	375	500

Standard compound: **white Polyurethane thermoplastic 92 ShA**

Standard back cover: **none**

Standard tooth cover: **none**

Standard cords: **S and Z torsion zinked steel**

Standard width tolerance: **+/- 0,5 mm**

Standard thickness: **4,5 +/- 0,3 mm**

Standard length tolerance: **+/- 0,8 mm/m**

Standard roll length: **100 m**

Standard inserts: **brass and stainless steel (M4)**

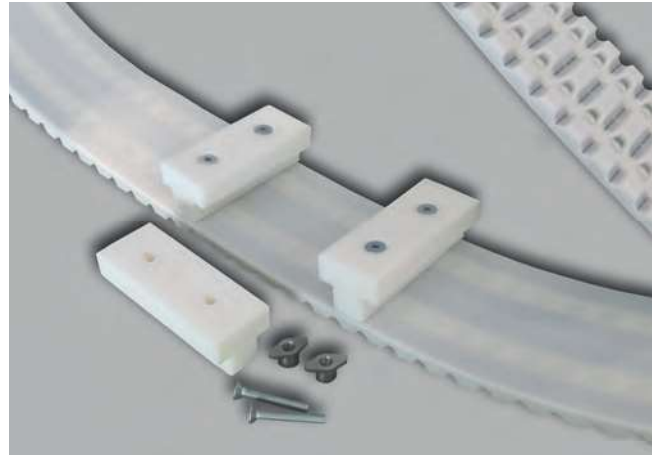

Tooth profile according ISO 17396

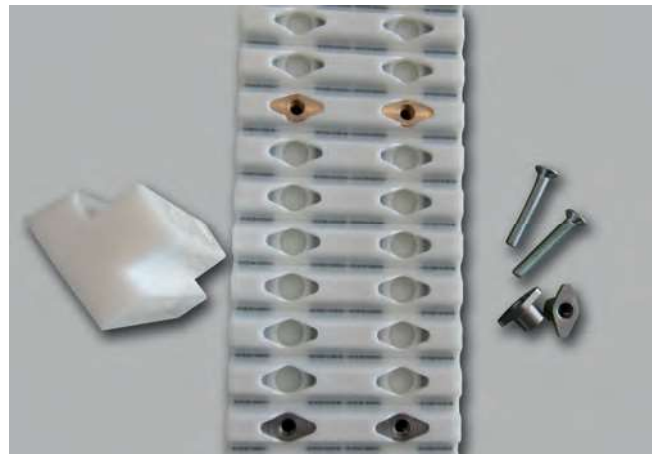
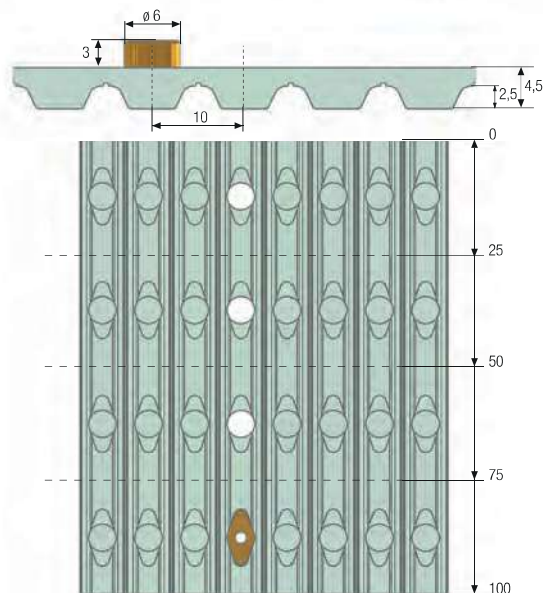

## TOOTH RESISTANCE

RPM (1/min)	0	20	40	60	80	100	200	300	400	500	750	1000	1500	2000	3000	4000	5000	8000
F <sub>p spec</sub> (N/cm)	<b>60</b>	<b>58</b>	<b>57</b>	<b>57</b>	<b>56</b>	<b>55</b>	<b>52</b>	<b>50</b>	<b>48</b>	<b>47</b>	<b>42</b>	<b>40</b>	<b>34</b>	<b>30</b>	<b>27</b>	<b>23</b>	<b>21</b>	<b>15</b>

Minimum suggested number of teeth in clamp for linear movement: 7

## TRACTION RESISTANCE

Belt width (mm)		25	50	75	100
Steel	Max Traction Load (N)	2850	5700	9000	12000
	Breaking Strength (N)	11400	22800	34200	45600
	Elongation at MTL (mm/m)	4	4	4	4

Average values

**FLEXION RESISTANCE**

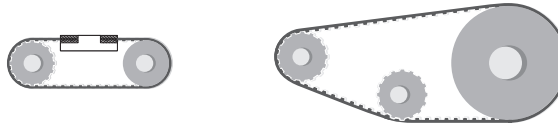

	$Z_{min}$	$Z_{min}$	Idler min dia (mm)
Standard steel cords	25	25	80

**JOINED BELT INFORMATION**

- Minimum splice length 900 mm
- Traction and tooth resistances = 50% less than open-end
- Joined belt can be used only in conveyor systems
- Minimum diameters according above table

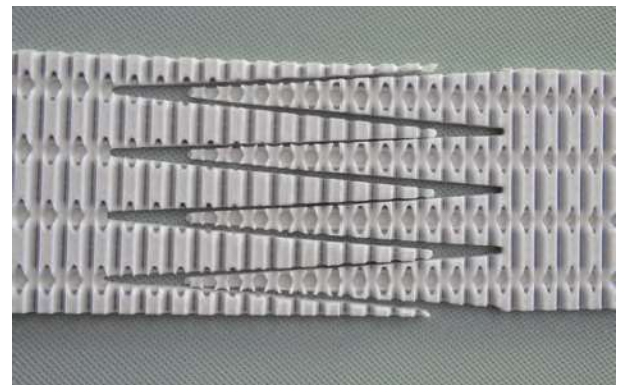

**PULLEYS** (for more details please see our pulleys catalogue)

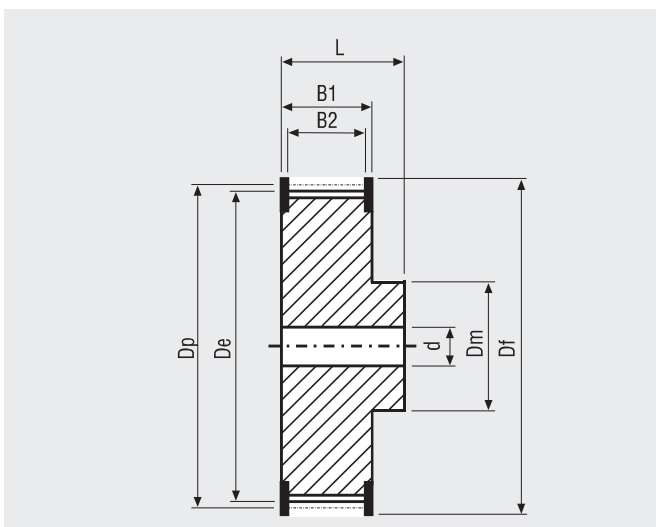

N° Teeth	Dp	De
25	79,58	77,73
26	82,76	80,91
27	85,94	84,10
28	89,13	87,28
30	95,49	93,65
32	101,86	100,01
36	114,59	112,74
40	127,32	125,48
44	140,06	138,21
48	152,79	150,94
60	190,99	189,14